

RACKMOUNT UPS

6kVA-10kVA

PF 0.9/1.0



Features

- Advanced DPS and 3-level technology with high frequency online double conversion technology help to stabilize the output voltage.
- Output Power factor 0.9/1.0 (optional)
- Active power factor correction (APFC), input power factor up to 0.99
- High efficiency 95% (up to 98% in ECO mode)
- Wide input range (110~288Vac) and frequency range (40~70Hz)
- Two modes of frequency convention: 50Hz input/60Hz output or 60Hz input/50Hz output
- Hot swappable battery for built-in battery series
- VRLA (Sealed lead-acid maintenance free battery) with 3 years battery life
- High charging current (optional for KRS series)
- Intelligent/Advanced battery management (ABM), 3-mode charging method with automatic floating/equalizing charge control, charger dormancy control, increasing battery life by 50%
- Linear derating in low voltage input reducing battery discharging time, extending the service life of battery

- Settable delayed start time when mains power is restored, reducing the impact on power grid or generator
 - Fan speed varies intelligently with temperature, reducing noise and extending its service life
 - Equipped with self-aging function
 - Compact internal layout, miniaturized the complete unit for small footprint
 - Manual bypass function is available for uninterrupted maintenance and service
 - LCD >1 inch +LED display and control (Voltage, current, load, fan fault, frequency, BAT...), multi-functional keys operation, friendly human-machine interface. LED display warning with sound and flash when UPS overload, connect battery failure and low battery
 - Display panel can be rotated 90°.
 - Powerful background software for parameters configuration
 - Effective software and hardware protection function, self-diagnostic function, robust abundant even log for check
- Available Options:**
- EPO, RS232 and smart slot included
 - Optional parallel function, SNMP card, USB, RS485, Dry contact

Rear panel

1. Fans
2. Parallel (optional)
3. RS232
4. EPO
5. USB (optional)
6. Temperature Compensation (optional)
7. GRD
8. Bypass breaker
9. Terminal and Cover
7. Battery pack

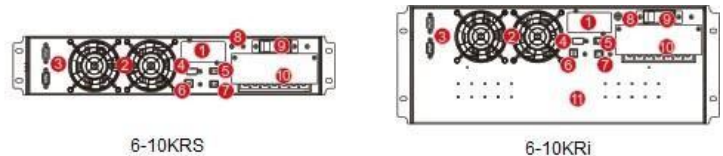

Easy for maintenance, hot-swappable battery for KRi series

SPECIFICATIONS

MODEL	HD-6KRi	HD-6KRS	HD-10KRi	HD-10KRS
Capacity (KVA/W)	6kVA/5400W 6kVA/6000W		10kVA/9000W 10kVA/10000W	
INPUT				
Input wiring	Single phase (1PH + N + PE)			
Rated voltage	208/220/230/240VAC			
Voltage range	88-176 Vac (linear derating between 30% and 100% load); 176-288 Vac (no derating)			
Rated frequency	50/60Hz (auto – sensing)			
Frequency range	40-70 Hz			
Power factor	≥0.99			
Bypass voltage range	-40% - +15% (settable)			
THDi	≤ 5%			
OUTPUT				
Output wiring	Single phase (L-N)			
Voltage	208 (PF0.9)/220/230/240VAC			
Voltage regulation	± 1%			
Frequency	Synchronized to bypass in mains mode; 50/60 Hz ±0.1Hz (battery mode)			
Waveform	Pure sine wave			
Power factor	0.9/ 1.0 (optional)			
THDv	≤1% (linear load); ≤4% (non-linear load)			
Crest factor	3:1			
Overload (bypass mode)	105-110% load for 10 mins; 110-125% load for 1 min; 125-150% load for 30s			
Overload (inverter/line mode)	≤ 110% load: transfer to bypass after 60 min; ≤125% load: transfer to bypass after 1 min; 150% load: transfer to bypass after 0.5min & shutdown after 1min			
BATTERIES				
DC voltage	192VDC (192-240VDC settable), VRLA type			
Inbuilt battery	16*12V7Ah	/	16*12V9Ah	/
Back up time 50% load	≥10mins	/	≥9mins	
Charging current	KRi: 1A; KRS: 5A (default). 1-5A settable, 12A (optional)			
Recharge time	KRi: 90% capacity restored in 8h; KRS: Depend on the battery capacity			
SYSTEMS				
Efficiency	≥94% at 100% load, max. 94.5% at 60% load; ≥98% in ECO mode			
Transfer time	0ms			
Protections	Short-circuit, overload, overtemperature, battery low voltage, overvoltage, undervoltage and fan failure			
Max. No of parallel	4			
Communications	EPO, RS232 (Standard), USB/ RS485/ Dry contacts/ SNMP (optional)			
Display and control	LCD+LED (LCD>1inch)			
	LCD display is divided into 3 areas: Icons, Value/settings and operation. Icons display: Load, BAT, Fan, Fault; Value/settings: Input voltage & frequency, output voltage & frequency, BAT voltage & capacity, number of BAT, load, temperature, software version, fault mode.....; Operations display: Standby mode, bypass mode, online mode, BAT mode, BATT (BAT self test) mode, Fault mode, CUCF (Frequency conversion) mode and ECO mode			
OTHERS				
Operation temperature	0 – 40°C			

Storage temperature	-25 – 55°C (without batteries)		
Relative humidity	0 – 95% (non-condensing)		
Altitude	≤ 1000m, derating 1% for each additional 100m		
IP rating	IP 20		
Noise level at 1m	≤ 55dB		≤ 58dB
Dimensions (W*H*D),mm	KRI: 440*660*176 (4U); KRS: 440*580*88 (2U)		
Net weight (kg)	58	12	63
			14

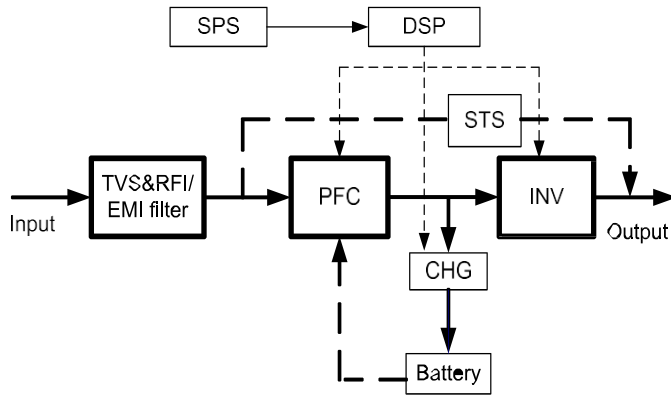

BATTERY RACK FOR ONLINE SINGLE PHASE

MODEL	BR16-7A	BR16-9A
BATTERY SYSTEM		
Battery type	VRLA 12VDC (sealed lead-acid maintenance free battery) with explosion-proof valve	
Typical battery recharging time	8h (to 90% of full capacity)	
Typical battery life	3 years, depend on discharging cycle and ambient temperature	
System voltage	192Vdc	
Battery quantity	16PCS (3U)	
Capacity	7AH/9AH	
PHYSICAL		
Battery Rack design	The battery cabinet is made of powder-coated iron. Safely suitable for electrical appliances	
ENVIRONMENT		
Operating environment	0°C – 40°C	
Relative humidity	0-95% (non condensing)	

* All specifications are subject to change without notice

* Custom-made specifications are acceptable